

Rotary Motion Sensor

PS-2120A

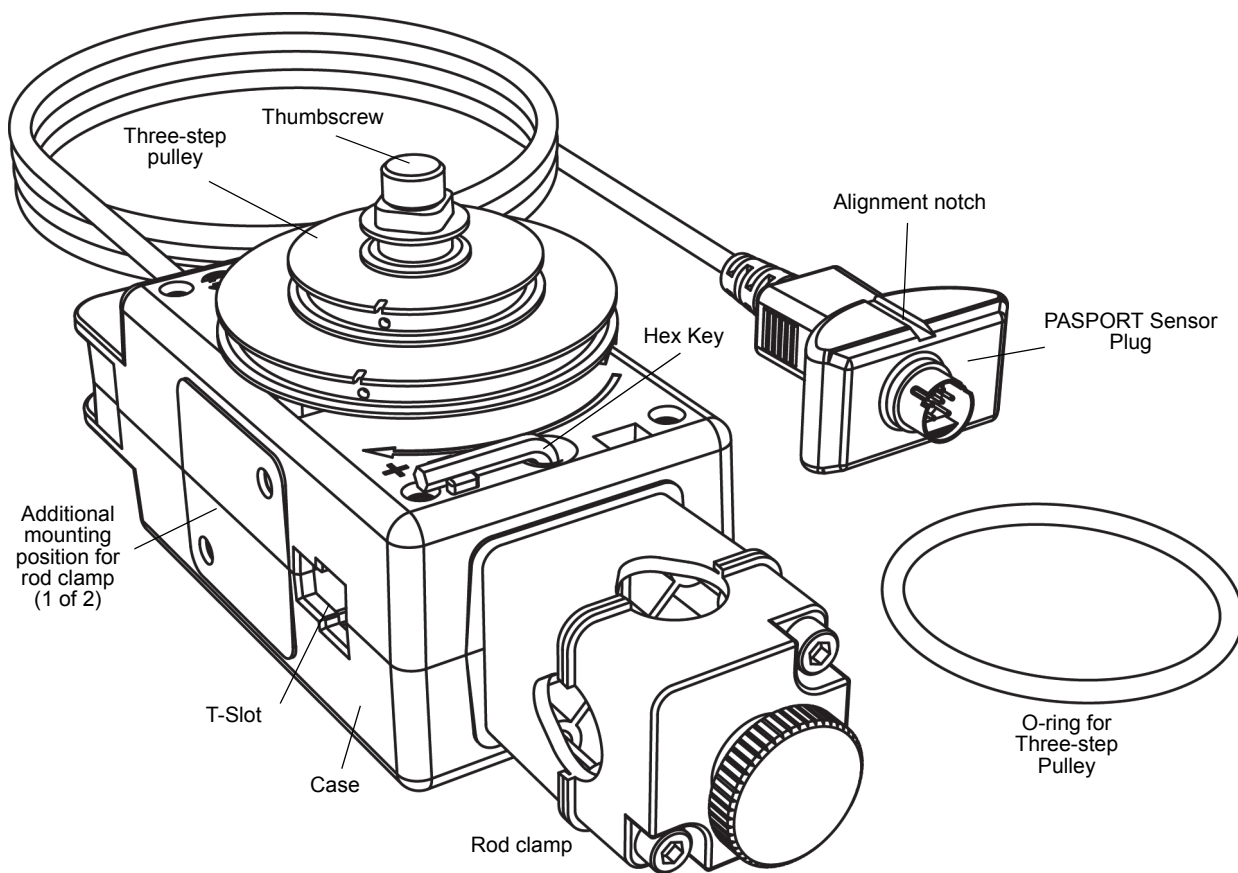

Equipment Included	Equipment Included
Rotary Motion Sensor (PS-2120A)	Three-step Pulley
Hex Key	Thumbscrew
O-ring	Rod Clamp

Required Items*	Part Number
PASCO PASPORT Compatible Interface	see www.pasco.com
PASCO Data Acquisition Software	see www.pasco.com

*See the PASCO catalog or the PASCO web site at www.pasco.com for more information.

For downloadable experiments, go to www.pasco.com and enter PS-2120A in the Search window.

Check the User Resources tab.

Equipment used with the sensor	Equipment used with the sensor
Mini-Rotational Accessory (CI-6691)	Physical Pendulum Set (ME-9833)
Linear Motion Accessory (CI-6888)	Torsion Pendulum Accessory (ME-6894)
Chaos/Driven Harmonic Accessory (CI-6689A)	Track String Adapter (ME-6569)
“A” Base Rotational Adapter (CI-6690)	Centripetal Force Pendulum (ME-9821)
Gyroscope Mounting Bracket (ME-8963)	Linear Translator (OS-8535)
Dynamics Track Mount Accessory (CI-6692)	Polarization Analyzer (OS-8533A)
Three-Step Pulley Accessory (CI-6693)	Computer-Based Thermal Expansion (TD-8579)
Rotating Platform (ME-8951)	Three-Axis Gyroscope (ME-8960)

Quick Start

- Plug the Sensor Plug into a PASPORT input port of a PASPORT-compatible PASCO interface (such as the 850 Universal Interface or SPARK SLS.)
- Start the PASCO data acquisition software (such as PASCO Capstone or SPARKvue). Set up a data display in the software.
- Click or press ‘START’ to begin recording data. Turn the shaft of the Rotary Motion Sensor.

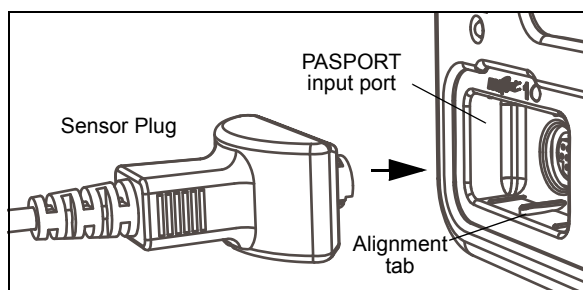

- **SETUP:** For information on setting up the data acquisition software and recording data, refer to the online help in the User’s Guide for the data acquisition software.

Introduction

The PASCO PS-2120A Rotary Motion Sensor is a versatile position and motion measuring device. It measures angles to a resolution of 0.09° , and detects the direction of motion. Markings on the outside of the case indicate which is the default positive direction. The optical code wheel inside the sensor has 4000 divisions per revolution (360°), and the maximum speed is 30 revolutions per second.

The sensor comes with a removable three-step pulley (10 millimeter (mm), 29 mm, and 48 mm diameters), and a rubber “O”-ring that fits into the largest diameter step. The three-step pulley can be attached to either end of the shaft, and can be placed large-diameter down or large-diameter up on the shaft. A tab on the inside of the pulley matches a notch on the outside of the shaft. The pulley has a notch and a small hole in the outer edge of the largest and second largest steps for attaching a string. The included hex key (allen wrench) allows the rod clamp to be removed from the end of the sensor and mounted on either the right-hand or left-hand side. The hex key fits in the storage hole near one end of the sensor and is held in place by a rubber “O”-ring inside the sensor.

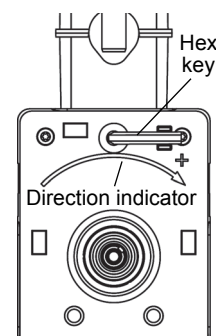

The end of the sensor where the cord exits the case has a platform for mounting a Super Pulley with Table Clamp (not included). The T-slot through the sensor is for inserting the optional Linear Motion Accessory rack (CI-6888). The gear teeth on the rack mesh with the gear teeth on the optical code wheel inside the sensor.

Mounting the Rotary Motion Sensor

The rod clamp fits rods up to 12.7 mm in diameter, such as the ME-8736 45 cm Stainless Steel Rod, and the rod clamp can be attached to the sensor in three different locations: at the end opposite to the cable and on either side of the case.

Use the included hex key to loosen the two screws that hold the rod clamp on the Rotary Motion Sensor case. The two screws do not need to come out all the way; they are held inside the rod clamp by small O-rings. Move the rod clamp to one of the additional mounting positions on either side of the case and use the hex key to tighten the screws in place.

It is possible to mount the Rotary Motion Sensor horizontally on a support rod with the Three-step Pulley facing up or facing sideways. You can mount the sensor vertically with the pulley facing forward. The sensor can also be mounted on the short rod that is part of the Dynamics Track Mount Accessory (CI-6692).

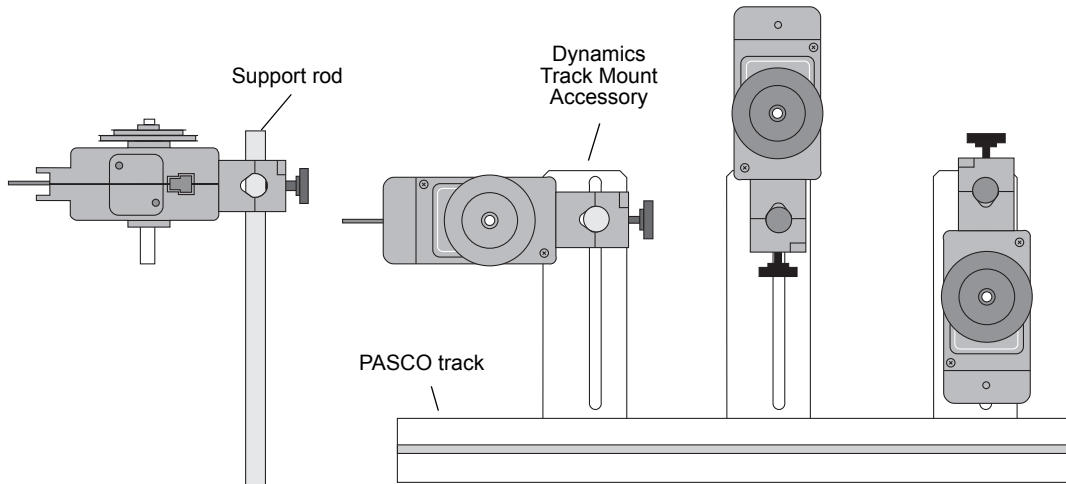
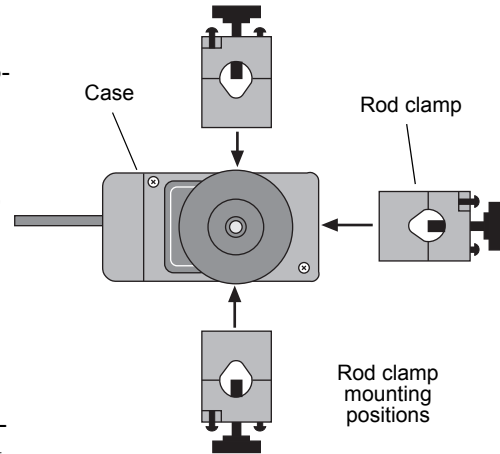

Mounting the Rotary Motion Sensor on a PASCO Track

Use the Dynamics Track Mount Accessory (CI-6692) to mount the Rotary Motion Sensor on a PASCO track. Slide the square nut of the Dynamics Track Mount Accessory into the T-slot on the side of the track. Adjust the position of the mounting rod on the Dynamics Track Mount Accessory.

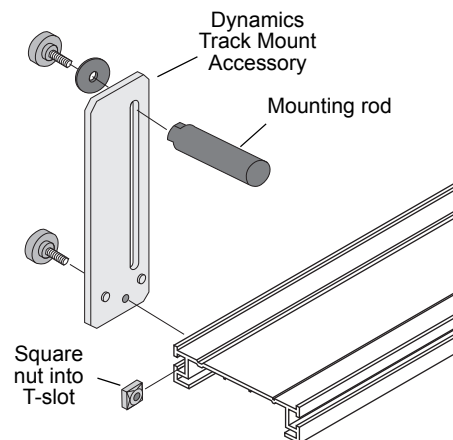
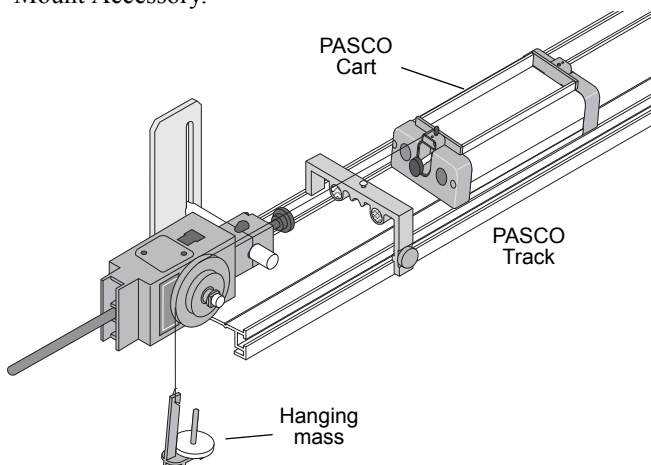

When mounted on a track as shown, a Rotary Motion Sensor could be used to measure the motion of a PASCO Cart as it is pulled by a string suspended over the Three-step Pulley of the sensor and attached to a hanging mass.

Mounting the Rotary Motion Sensor to a Large “A” Base

The Rotary Motion Sensor can be mounted on the base of the Rotating Platform (ME-8951) using the “A” Base Rotational Adapter (CI-6690, available separately).

The “A” Base Rotational Adapter includes an adapter bracket, a three-step pulley, a drive belt (“O” ring), and a shoulder screw.

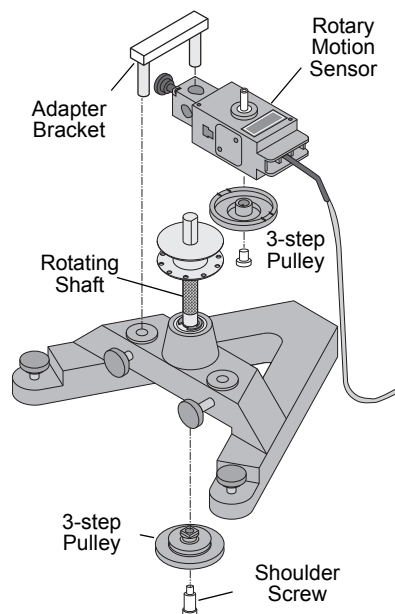
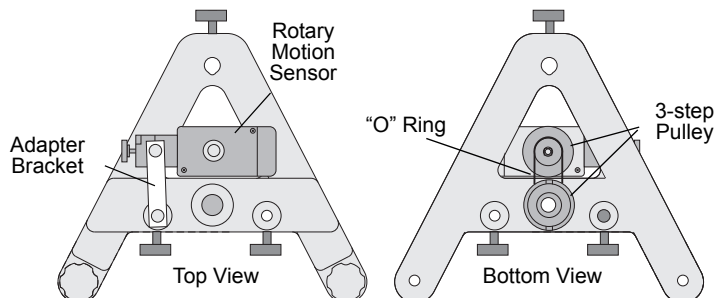

See the PASCO web site at www.pasco.com for more information.

Mounting the Rotary Motion Sensor to a Gyroscope

Use the Gyroscope Mounting Bracket (ME-8963, available separately) to mount the Rotary Motion Sensor to the Three-Axis Gyroscope (ME-8960). Remove the gyroscope assembly from the vertical shaft of the large “A” base. Mount the Gyroscope Mounting Bracket onto the vertical shaft. Remove the rod clamp and the three-step pulley from the Rotary Motion Sensor, and mount the sensor on the Gyroscope Mounting Bracket with the thumbscrews included with the bracket. Mount the slotted guide arm onto the shaft of the Rotary Motion Sensor. Replace the gyroscope assembly on the vertical shaft.

See the PASCO web site at www.pasco.com for more information.

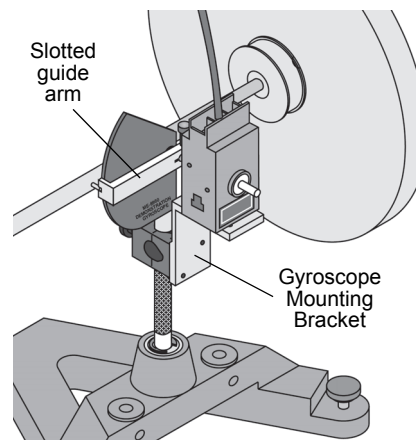

Attaching Accessories to the Rotary Motion Sensor

Attaching the Mini-Rotational Accessory to the Rotary Motion Sensor

To mount the rod of the Mini-Rotational Accessory to the Rotary Motion Sensor, orient the 3-step Pulley so that the large diameter step is away from the sensor case. The large diameter step has two pair of rod guides opposite each other on the top edge. Align the rod with the rod guides and use the captive screw in the center of the rod to attach the rod and pulley onto the sensor's shaft.

Attach the center of the rod to the 3-step Pulley and shaft and mount the cylindrical masses at the ends of the rod to investigate the rotational inertia (moment of inertia) of point masses.

Attach the end of the rod to the 3-step Pulley and shaft. Mount a cylindrical mass on the rod to use the rod as a pendulum. Investigate the period of oscillation of the pendulum when the amount of mass or the position of the mass is changed. Investigate the period of oscillation as the amplitude of the swing is changed.

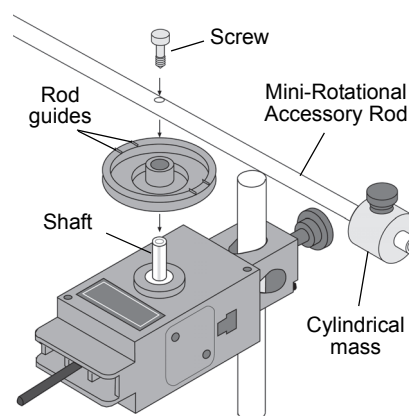

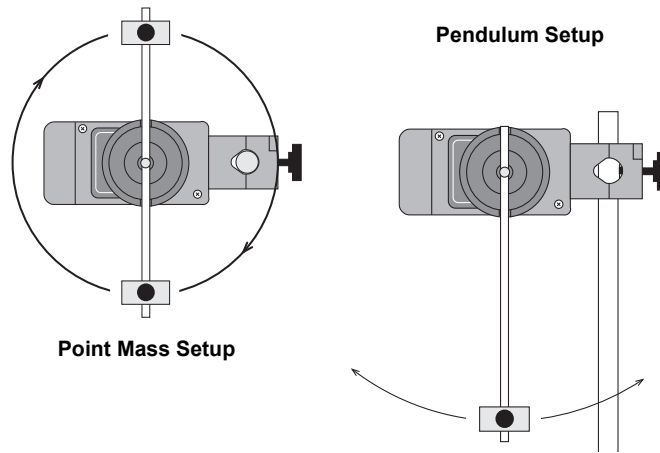

Attaching the Chaos/Harmonic Motion Accessory to the Rotary Motion Sensor

The Chaos/Harmonic Motion Accessory (CI-6689A) is a driven damped physical pendulum. Various types of phase plots can be made as the driving frequency, driving amplitude, initial conditions, and amount of damping are varied.

The Magnetic Damping Attachment attaches to either side of the Rotary Motion Sensor in the same way as the rod clamp is attached. A small cylindrical mass attaches to the threaded hole in the edge of the disk to form the physical pendulum. Mount the disk with the small mass to the 3-step Pulley and shaft.

One way to drive the Chaos/Harmonic Motion Accessory is with the Mechanical Oscillator/Driver (ME-8750) and a power supply. Any PASCO track can be used to mount and align all the components.

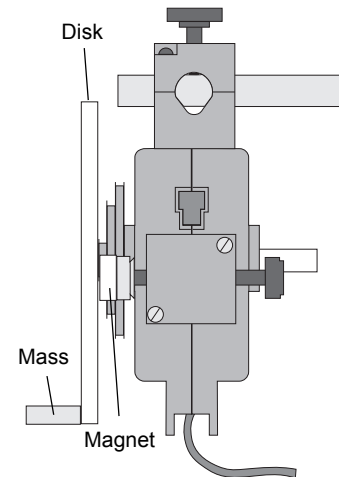
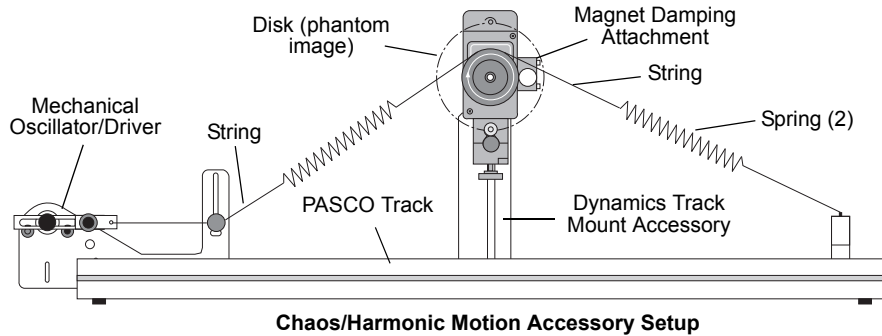

Using the Mini-Rotational Disk

For other rotational inertia experiments, mount the Rotary Motion Sensor with the disk horizontal. Mount a Super Pulley with Clamp (ME-9448B) on the platform at the cable end of the sensor. To provide a known torque, wrap a string around one of the steps of the 3-step Pulley. Arrange the end of the string over the Super Pulley and attach a hanging mass.

Perform a conservation of angular momentum experiment by dropping the ring onto the disk as it is rotating.

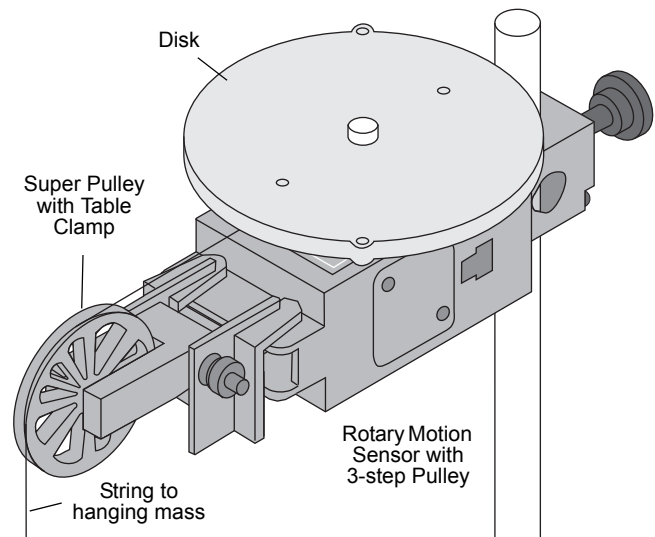

Download-able Experiments

Experiments for the Rotary Motion Sensor in electronic format are available to download from the PASCO web site at www.pasco.com. Go to the PASCO web site at www.pasco.com and enter PS-2120A in the Search window. Check the User Resources tab.

Three suggested experiments are:

- Rotational Inertia of a Point Mass
- Rotational Inertia of Disk and Ring
- Conservation of Angular Momentum.

Using the Rotary Motion Sensor with Data Acquisition Software

- Plug the Sensor Plug into a PASPORT input port of a PASPORT-compatible PASCO interface (such as the 850 Universal Interface, Xplorer GLX, or SPARK Science Learning System (SLS)).
- Turn on the PASPORT-compatible interface.
- For the PASPORT-compatible interface, start the PASCO Capstone software.
- For the SPARK SLS, if the sensor is plugged in, the SPARKvue software will start automatically when you turn on the interface. The SPARKvue software will show the SPARK SLS Home Screen with the Rotary Motion Sensor.

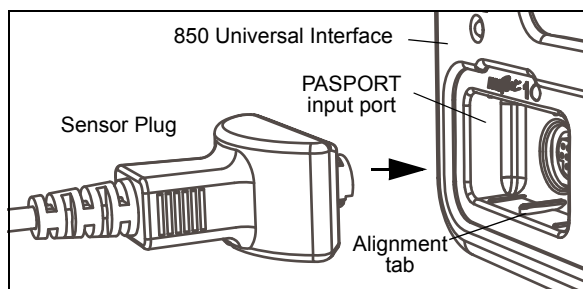

PASCO Capstone Setup

- In PASCO Capstone, click “Hardware Setup” in the Tools palette to open the Hardware Setup panel. Confirm that the Hardware Setup panel shows the interface you are using and the icon of the Rotary Motion Sensor.

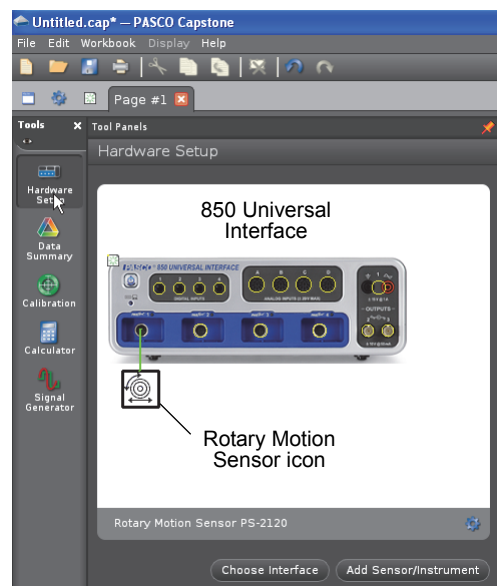

Capstone Hardware Setup panel

- Set up a data display. For example, drag the Graph icon from the Displays palette onto the workbook page, or double-click the icon to create a Graph display..

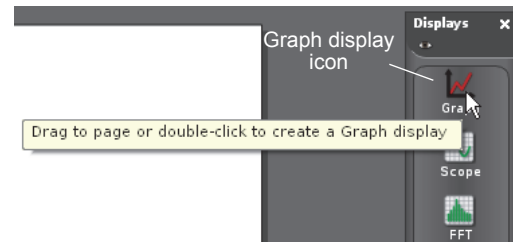

Create a Graph display

- Set up the Graph display to show Angular Velocity (rad/s) on the vertical axis. Click the “Select Measurement” menu button on the vertical axis and pick Angular Velocity (rad/s) from the menu. Time (s) automatically shows on the horizontal axis.
- Click ‘Record’ in the lower left corner of the PASCO Capstone window to begin recording data. (The “Record” button changes to “Stop”.)



Click “Record”

- Turn the shaft of the Rotary Motion Sensor back-and-forth. View the data in the Graph display.
- Click “Stop” to end data recording.

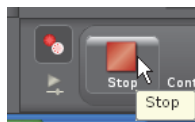

Click “Stop”

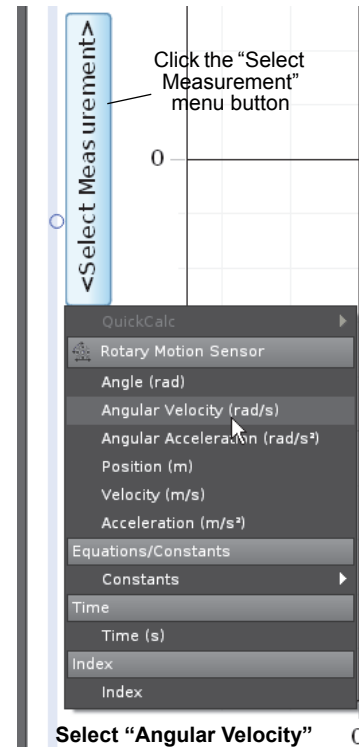

Select “Angular Velocity”

- SETUP:** For detailed information on setting up the data acquisition software and recording data, refer to the User’s Guide and the online help for the data acquisition software.

SPARK SLS Setup

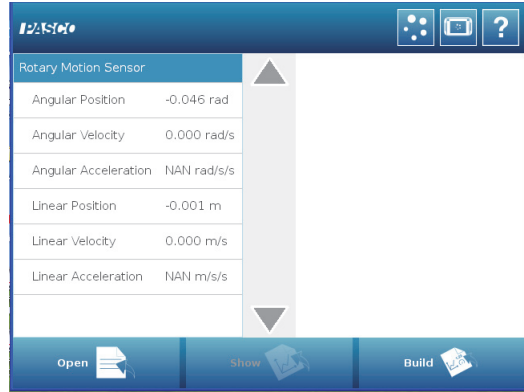

- In the Home Screen, press “Angular Velocity” and then press the Show button () to open a graph display.

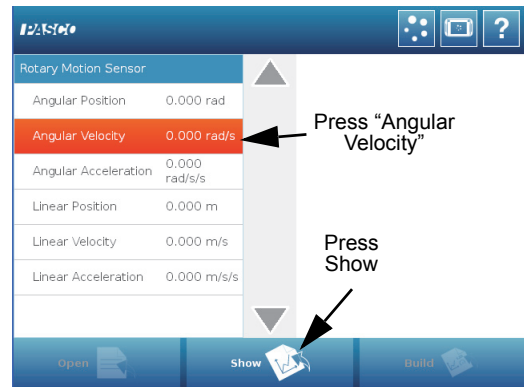

SPARK SLS Home Screen for the Rotary Motion Sensor



Press “Angular Velocity” and then press “Show”

- Press the Start button () to begin recording data. Turn the shaft of the sensor and view the data in the display.
- Press the Stop () button to end data recording.
- SETUP:** For detailed information on setting up the data acquisition software and recording data, refer to the User’s Guide and the online help for the data acquisition software.

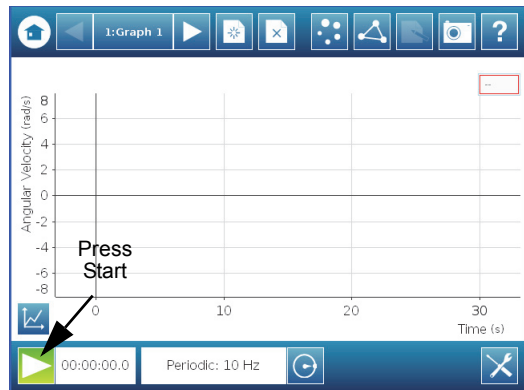

Press “Start”

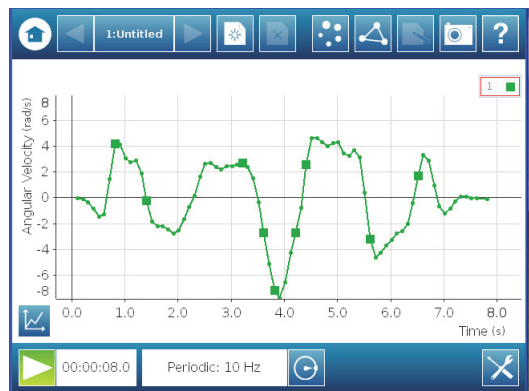

Turn the Rotary Motion Sensor shaft

Technical Support

For assistance with any PASCO product, contact PASCO at:

Address: PASCO scientific
10101 Foothills Blvd.
Roseville, CA 95747-7100

Web: www.pasco.com

Phone: +1 916-462-8384 (worldwide)
877-373-0300 (U.S.)

Email support@pasco.com

Limited Warranty For a description of the product warranty, see the PASCO catalog. **Copyright** The PASCO scientific *Instruction Manual* is copyrighted with all rights reserved. Permission is granted to non-profit educational institutions for reproduction of any part of this manual, providing the reproductions are used only in their laboratories and classrooms, and are not sold for profit. Reproduction under any other circumstances, without the written consent of PASCO scientific, is prohibited. **Trademarks** PASCO, PASCO Capstone, and PASPORT are trademarks or registered trademarks of PASCO scientific, in the United States and/or in other countries. For more information visit www.pasco.com/legal.

Product End of Life Disposal Instructions:

This electronic product is subject to disposal and recycling regulations that vary by country and region. It is your responsibility to recycle your electronic equipment per your local environmental laws and regulations to ensure that it will be recycled in a manner that protects human health and the environment. To find out where you can drop off your waste equipment for recycling, please contact your local waste recycle/disposal service, or the place where you purchased the product.

The European Union WEEE (Waste Electronic and Electrical Equipment) symbol (to the right) and on the product or its packaging indicates that this product **must not** be disposed of in a standard waste container.

